

EV CHARGING STATION

— User manual —



* Please read this manual carefully before use and keep it for future use.

Contents

Foreword.....	1
Safety Precautions.....	1
Chapter 1 Product Introduction.....	2
1.1 Product Introduction	2
1.2 Description of Main Parameters	3
1.3 Product Performance and Features.....	4
1.4 Operating Environment of Product	5
1.5 Product Structure.....	5
Chapter 2 Instructions for Installation and Operation.....	7
2.1 Open-box Inspection	7
2.2 Preparation for Installation.....	7
2.3 Installation Process	8
2.4 Power-on Inspection and Debugging of Equipment	12
2.5 OPERATION OPTION SETTINGS.....	13
2.6 Charging Operation.....	13
Chapter 3 Common Troubleshooting.....	15
Chapter 4 How to use the APP.....	16
Chapter 5 Load Balance.....	17
WARRANTY	18

Foreword

Thank you for your support for our products. Our company focuses on the field of new energy electric vehicle charging and is committed to providing customers with excellent charging equipment and complete charging operation solutions.

The electric vehicle charging pile developed and produced by our company has advanced functions, stable performance, wide application of use, strong practicability, mature charging station construction and operation solutions, and has a good reputation in the industry.

Safety Precautions

- 1) Please do not put flammable, explosive or combustible materials, chemicals, combustible vapor and other dangerous goods near the charging pile;
- 2) Keep the charging gun head clean and dry. If it is dirty, please wipe it with a clean dry cloth. It is strictly forbidden to touch the charging gun core with hands when it is live
- 3) It is strictly forbidden to use the charging pile when the charging gun or the charging cable is defective, cracked, worn, broken, or the charging cable is exposed. If any defect is found, please contact the staff in time;
- 4) Please do not try to dismantle, repair or modify the charging pile. If it is needed to repair or modify it, please contact the staff. Improper operation may cause damage, water leakage, and electric leakage to the equipment;
- 5) In case of any abnormal situation during the use, press the emergency stop button immediately to turn off all input and output power supplies;
- 6) In case of rain and thunder, please charge carefully;
- 7) Children shall not get close to and use the charging pile during charging to avoid injury.
- 8) In the process of charging, the vehicle is forbidden to drive and can be charged only when it is static.
The hybrid electric vehicle shall flame out before charging.

Chapter 1 Product Introduction

1.1 Product Introduction

This product is a single or three-phase AC charging pile, mainly used for AC slow charging of electric vehicles. The design of the product is highly simple. It provides card swiping charging modes, with charging protection function. The principle of industrial design is adopted for the equipment, with the original function of toppling protection to ensure safe operation of the equipment. The protection level of the whole equipment reaches IP55, and it has good dustproofing and waterproofing functions and can be safely operated and maintained outdoors.



Figure 1 Outside View of Charging Pile

1.2 Description of Main Parameters

Detailed Specification	Product Model	7kW	11kW	22kW
Appearance structure	Product name	1 phase Wallbox	Three phase Wallbox	
	Product type	Home version		
	Shell material	Black tempered glass panel, PC body		
	Equipment dimension	200*200*100mm (L*W*H)		
	Installation method	Wall-mounted\portable		
	Wiring method	Getting in and going out from the bottom		
	Equipment weight	<3kg	<3kg	
Electrical indexes	Input voltage	110V-250V	380V-400V	
	Input frequency	50/60Hz		
	Max. power	7kW	11kW	22kW
	Output voltage	220V	380V	380V
	Output current	32A	16A	32A
	Standby power consumption	<3W		
Environmental indexes	Applicable scene	Indoor / Outdoor		
	Operating temperature	-30°C ~ +55°C		
	Operating humidity	5% ~ 95%, without condensation		
	Height above sea level	<2000m		
	Protection level	IP54		
	Cooling method	Natural cooling		
	Safety certification	IEC 61851		
	MTBF	100,000 hours		
Special protection	UV protection design			
Safety design	Over-voltage protection, under-voltage protection, overload protection, earth leakage protection, grounding protection, over-temperature protection, low-temperature protection, lightning protection			

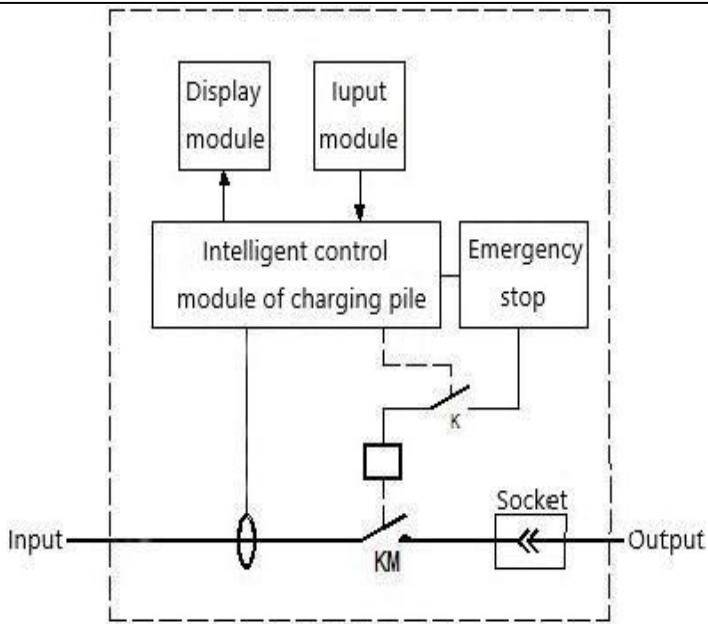

Figure 2 Product Functional Block Diagram

1.3 Product Performance and Features

Product performance

- Modular design, stable and reliable: Modular design principle is adopted for the equipment, with flexible configuration and convenient maintenance.
- All-round protection and safe operation: It has over-voltage protection, under-voltage protection, overload protection, earth leakage protection, grounding protection, over-temperature protection, low-temperature protection, lightning protection and toppling protection, ensuring safe and reliable operation of the equipment and effectively preventing accidents.
- Easy to use: Easy to install and use.

Product features

- High protection level: IP55, supporting outdoor harsh environment, not needing to set up additional canopy, etc.
- Original toppling protection design: When the inclination of the equipment exceeds 30° due to accidents in the electrifying process, the power supply will be turned off immediately and the output shall stop to protect the personal and equipment safety.
- Low power consumption: The standby power consumption of the equipment is as low as 3W, energy saving and low consumption.

- Strong compatibility: The equipment is simple home version, and can be configured in plug and play operation mode with software. Only the software needs to be set, while the hardware does not need to be transformed.
- Simple structure: Occupying a small space, lightweight, the equipment can be fixed or portable,

1.4 Operating Environment of Product

- Height above sea level: ≤2000m
- Operating ambient temperature of equipment: -30°C~50°C
- Relative air humidity: 5%~95%
- Indoor/Outdoor operation
- The pile surroundings shall keep away from flammables and explosives

1.5 Product Structure

EV Charger station External Components

1. Display Screen
2. Current regulating
3. Swipe Card Area
4. Time delaying
5. Emergency Button

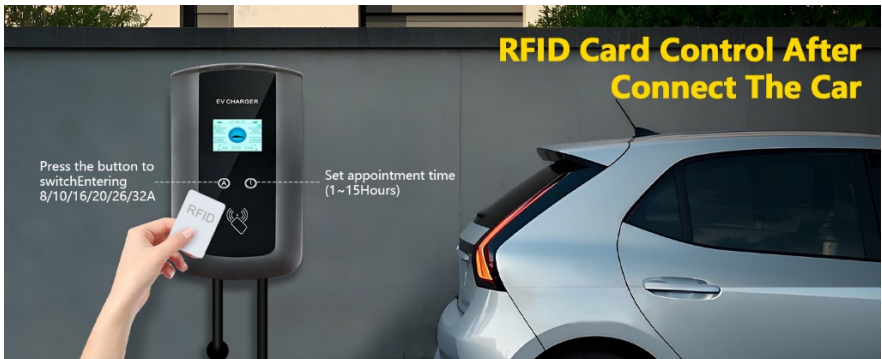
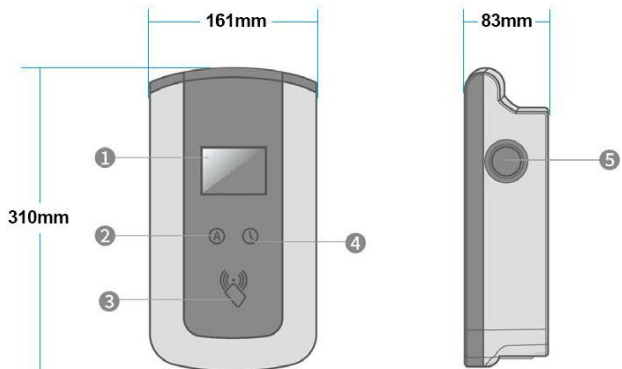



Chapter 2 Instructions for Installation and Operation







2.1 Open-box Inspection

After the AC charging pile arrives, open the package and check the following items:

- Visually inspect the appearance and check whether the AC charging pile is damaged in transit. If there is any damage, please inform the carrier immediately.
- Check whether the accompanying accessories are complete and correct according to the packing list. If the accessories are missing or the model is not consistent, keep the on-site records in time, and inform the local office of the Company immediately.

2.2 Preparation for Installation

Installation Tools

Tool Name	Picture	Main Function
Insulation torque spanner		Fastening the bolts
Combination spanner		Fastening the bolts
Hydraulic tongs		Pressing OT terminals
Diagonal pliers		Cutting off the cables
Multi-meter		Checking electrical connection and electrical parameters
Cross screwdriver (PH2×150mm, PH3×250mm)		Fastening the screws
Insulation adjustable spanner		Fastening the bolts

Preparation of Cables

The following cable specifications for charging pile power supply are recommended:

Cable Name	Cable Specification	Length	Reserve
Power line	Single-phase power cable of 3*6mm ² and above	Subject to the specific construction length	
Circuit breaker	One-phase 40A circuit breaker		

2.3 Installation Process

- 1) Wiring, installation of wall-mounted bracket

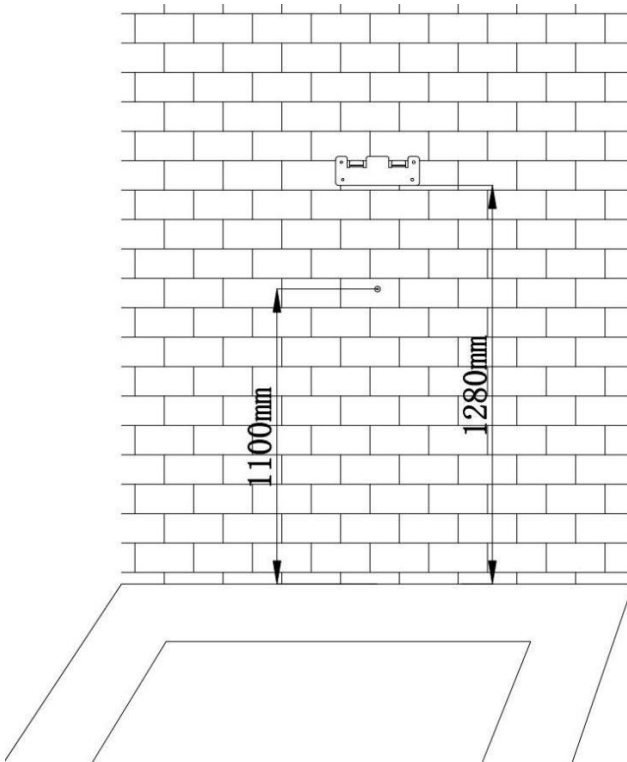

2) Incoming installation of charging pile

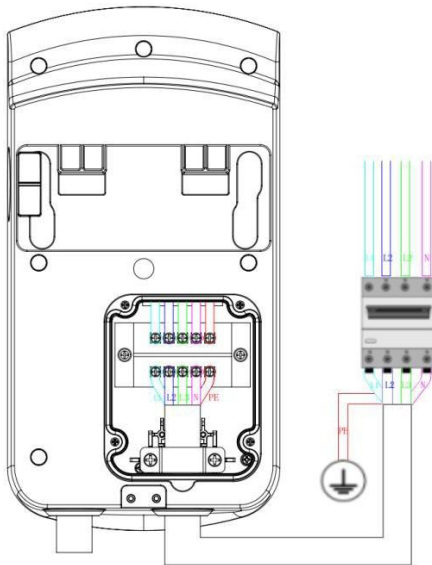
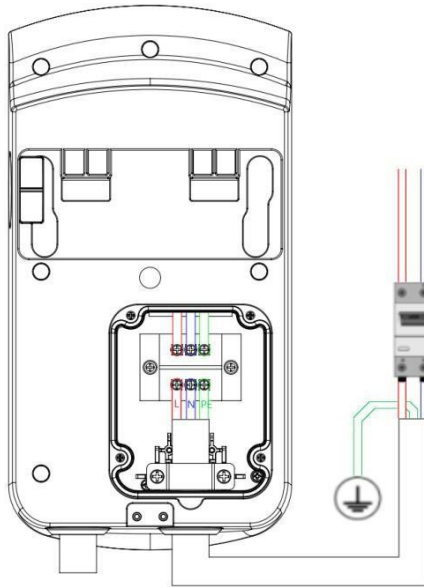

3) Wall mounting and fixing

Hang the mounting hole at the back of the equipment onto the fixed screw on the wall from the front and fix it;

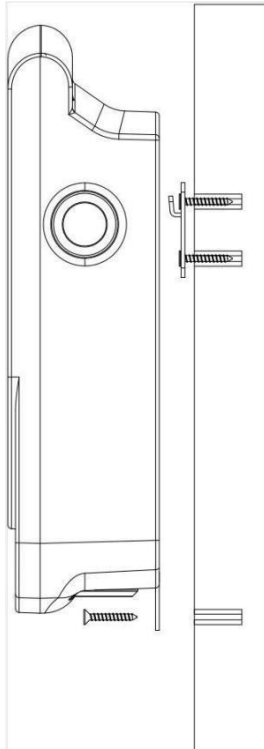

4) Installation of gun base

Install the gun base under the equipment, with an installation height of 800mm from the ground

5) The installation is over, and the effect is as shown in the figure below:

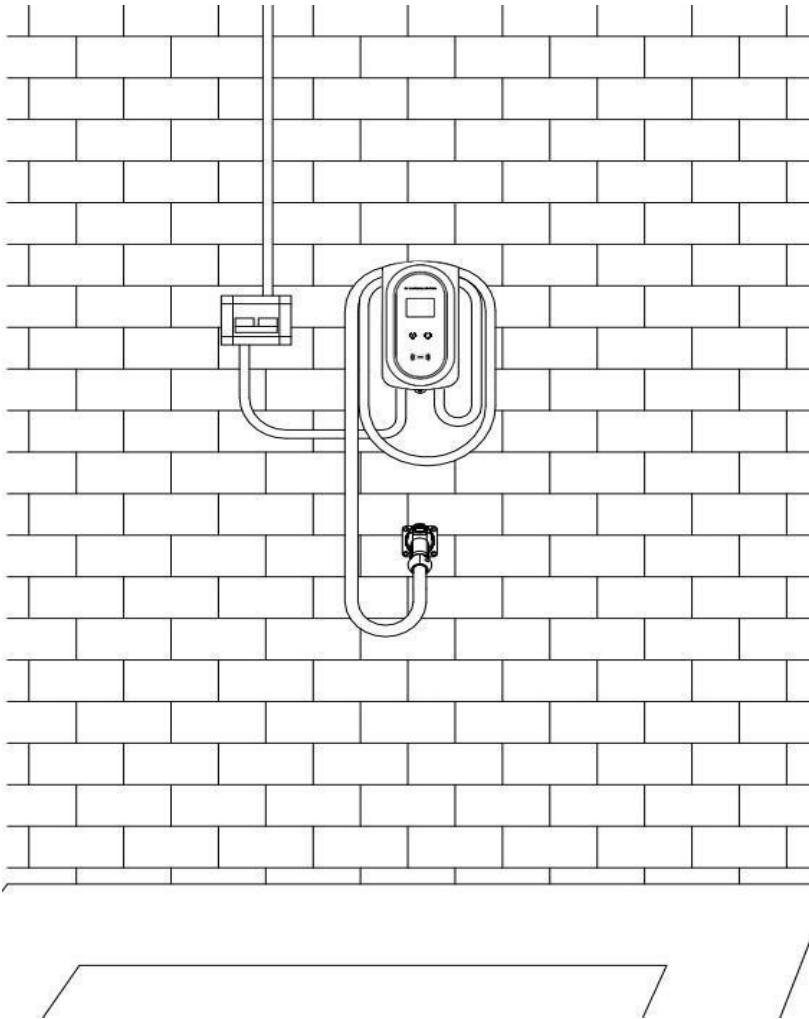

2.4 Power-on Inspection and Debugging of Equipment

1) Pre-operation inspection

Please carefully check and ensure the following items before operation:

- The installation position of AC pile is convenient for operation and maintenance
- The AC pile and accessories are correctly connected and firmly installed
- The type selection of earth leakage circuit breaker at AC incoming terminal is reasonable
- There are no external objects or parts left on the top of AC pile

2) Equipment power-on

1. Confirm that all the above items meet the requirements before operation
2. Close the earth leakage circuit breaker of incoming power line
3. Power-on of AC pile: There is about 5 seconds of power-on self-test time, and the indicator lamp will be on in red, yellow and green alternately, 1 second respectively
4. After power-on self-test, observe the status of LED indicator lamp.
 - Normal standby: The green light is breathing, on for 1S, and off for 3S

- **Equipment fault: The red lamp is always on**

5. CONTROL BOX SCREEN DISPLAY



2.5 OPERATION OPTION SETTINGS

- a. Touch the Button A to Switch Current
- b. Touch the CLOCK button to schedule charging, it's able to schedule 0/1/2/3/4.../15 hours before charging.

Note: When an "Error Reset" appears, press and turn the red button to reset the charger. Which cause resets on wifi connection after this action.



2.6 Charging Operation

1) Charging connection

After the electric vehicle owner stops the electric vehicle in place, take down the charging gun from the pile and insert it into the charging base of the electric vehicle. Please carefully check whether it is inserted in place to ensure reliable connection.

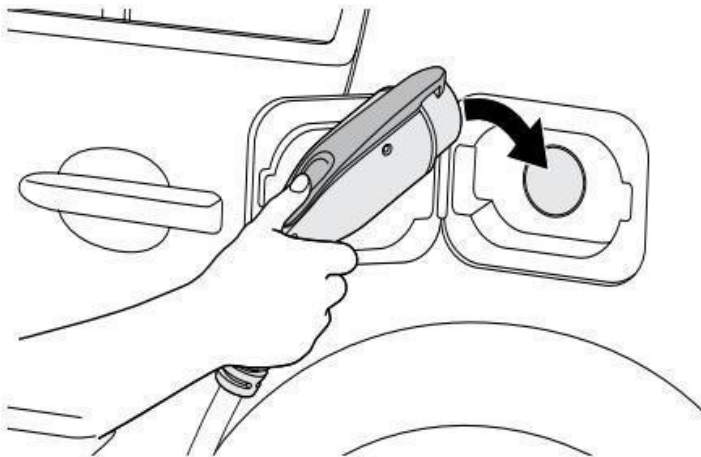

2) Charging control

For this standard charging pile, ensure that the charging gun is reliably inserted into the electric vehicle, and it receives the upper charging instruction before charging the electric vehicle. The upper charging instruction may come from CPU or M1 contactless card,

Charging by swiping the card

Charging users need to apply for the charging card to the device manager to charge their vehicles; After parking the vehicle, connect to the charging gun and swipe the charging card in the card swiping area on the equipment panel, and keep a distance of not less than 2MM between the card and the card swiping area. Stay for about 3S, and then you can charge your electric vehicle;

3) Charging stops

When the charging pile is in working state, the vehicle owner can end charging in the following ways:

1. Swipe the card to end charging, and when the vehicle is unlocked, draw the gun;

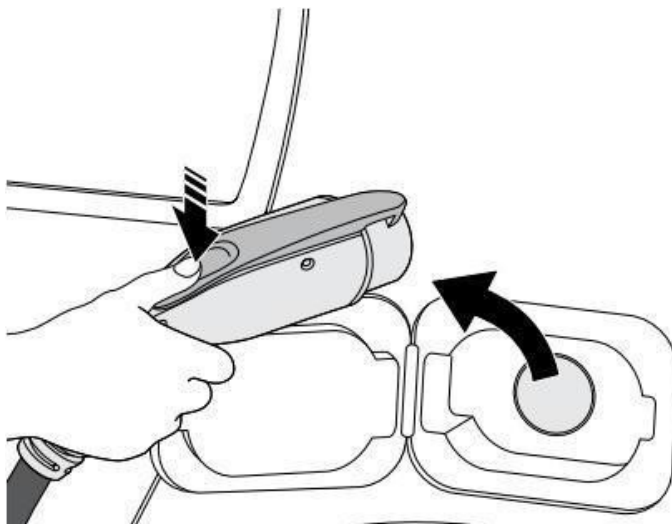

Chapter 3 Common Troubleshooting

Fault Name	Possible Causes of Faults	Suggestions
AC over-voltage	AC input voltage is too high	<ol style="list-style-type: none"> 1. Ask an electrician to test the input voltage of air switch 2. If the actual voltage is greater than 264Vac for a short time, wait for the peer-to-peer network to recover to the normal voltage range. 3. If the actual voltage is greater than 264Vac for a long time, please contact the power supply department 4. If the actual voltage is less than 264Vac, please contact us;
AC under-voltage	AC input voltage is too low	<ol style="list-style-type: none"> 1. Ask an electrician to test the input voltage of air switch 2. If the voltage is lower than 85Vac for a short time, wait for the peer-to-peer network to recover to the normal voltage range. 3. If the actual voltage is less than 85Vac for a long time, please contact the power supply department 4. If the actual voltage is greater than 85Vac, please contact us;
AC over-current	AC input current is too high	<ol style="list-style-type: none"> 1. Immediately turn off the leakage/over-current protection switch of the distribution box 2. Check whether there is a low-impedance connection between two output lines of AC pile 3. After the above problems are eliminated, power on again. If the fault still exists, please contact us
Over-temperature	The interior temperature is greater than 85°C	<ol style="list-style-type: none"> 1. Check the installation environment of AC pile to see whether there is heating equipment or devices nearby, and ensure that the ambient temperature is below 60°C 2. If the fault can't be eliminated, please contact us
Leakage current exceeds the limit	The leakage current is greater than 30mA	<ol style="list-style-type: none"> 1. Immediately disconnect the leakage/over-current protection switch of the distribution box 2. Check whether the output line of AC pile is damaged or has low-impedance connection to the ground 3. After the above problems are eliminated, reset the reset switch of leakage current protector, and power on again. If the fault still exists, please contact us
Leakage current sensor is abnormal	The sensor for detecting the leakage current is abnormal	<ol style="list-style-type: none"> 1. Immediately disconnect the leakage/over-current protection switch of the distribution box 2. Check whether the output line of AC pile is damaged or has low-impedance connection to the ground 3. After the above problems are eliminated, power on again. If the fault still exists, please contact us
Ground fault	The input/output grounding is poor or the input I/N connection is reverse	<ol style="list-style-type: none"> 1. Immediately disconnect the leakage/over-current protection switch of the distribution box 2. Check whether the grounding of AC pile input/output line is normal and whether the input L/N is connected according to normal sequence 3. After the above problems are eliminated, power on again. If the fault still exists, please contact us
Connection of charging gun is abnormal	CC/CP Connection of charging gun is abnormal	<ol style="list-style-type: none"> 1. Check whether the connection of charging gun is correct and reliable 2. If the fault still exists, please contact us

Chapter 4 How to use the APP

You can search for “Tuya Smart “APP in Google play or Apple Store

Make sure charger and mobile phone in the same Wifi network (5G Wifi is not supported) and cellophane close to the charger in the Bluetooth connect area.

When the device is powered on, the Tuya Smart APP is opened, and the network status of the charging device is displayed as follows, it indicates that the network configuration operation is required. (1)

After the charging device is successfully connected to the network, the network status of the charging device is displayed as follows (2): The network has been configured successfully, but the Wifi is not connected to the Internet. The network status of the charging device is displayed as follows (3)



Open the Tuya Smart App, touch the plus sign in the upper right corner, and automatically discover the device, open the permissions, and start searching, as follows. Enter the device's working Wifi and password, wait for the charging device to be successfully added to the network, and enter the App charging display interface.

Note: negligently press red button can clear internet record on APP control through wifi, or change home WIFI password, the network must to be reconfigured as first time.

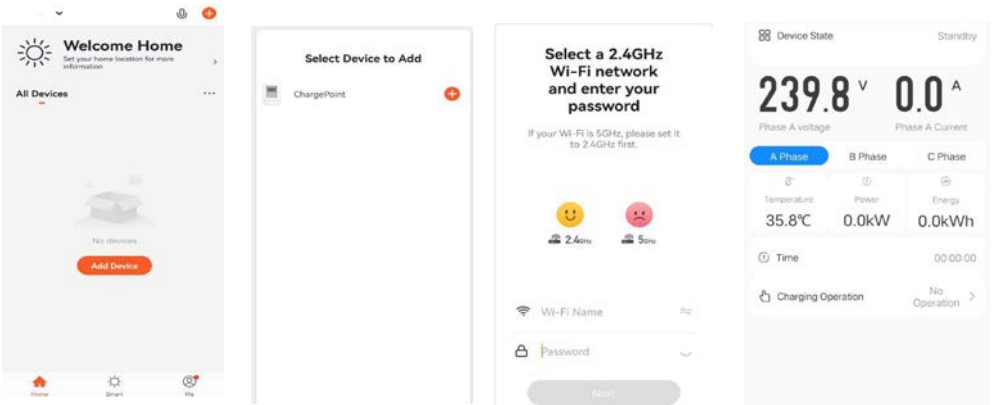

Chapter 5 Load Balance

Install the external current sensor according to the instructions in the diagram below.

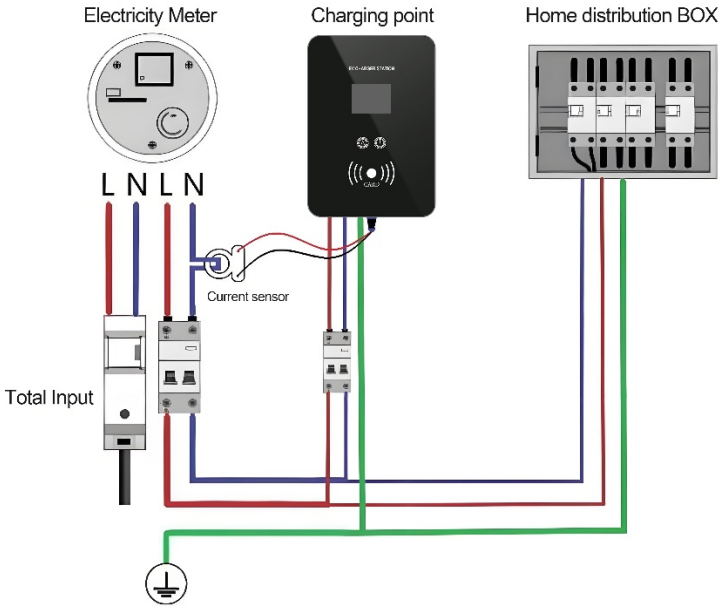

After the installation is completed, please long press the A button and swipe the card to enter the background (as shown in Figure 1), select to enter the Charge Plan interface (as shown in Figure 2), and set Total Current to the total household current.



WARRANTY

Company ensure the production of portable charging line are through strict quality inspection, within one year from the date of purchase under the correct use of caused by product quality problems, the company will give users the quality maintenance.

Any user due to their improper handling, installation, use and maintenance, secretly negligence or because of natural disasters, lead to products direct damage or cannot be used properly, are out of place in the product warranty.

This warranty does not include the freight returned to the factory maintenance.

The warranty is only valid to the original purchaser and is not transferable.