

200GBASE-SR4 QSFP56 Optical Transceiver Module

Features

- ✓ Hot-pluggable QSFP56 form factor
- ✓ Built-in 200G PAM4 CDRs on Tx & Rx data paths
- ✓ Supports 212.5Gb/s aggregate bit rates
- ✓ Supports 103.1Gb/s aggregate bit rates if required^{Note1}
- ✓ Low power dissipation < 3.5W
- ✓ RoHS-6 compliant (lead-free)
- ✓ Commercial case temperature range of 0°C to 70°C
- ✓ Single 3.3V power supply
- ✓ Maximum link length of 70m on OM3 MMF and 100m on OM4 & OM5 MMF
- ✓ Uncooled 4 channels 850nm VCSEL array
- ✓ 4 channels PIN photo detector array
- ✓ 200GAUI-4 electrical interface
- ✓ Single MPO12 receptacle
- ✓ I2C management interface
- ✓ Supports analog parameters monitoring



Applications

- ✓ IEEE 802.3cd 200GBASE-SR4 Ethernet (PAM4)
- ✓ IEEE 802.3bm 100GBASE-SR4 Ethernet (NRZ)^{Note1}

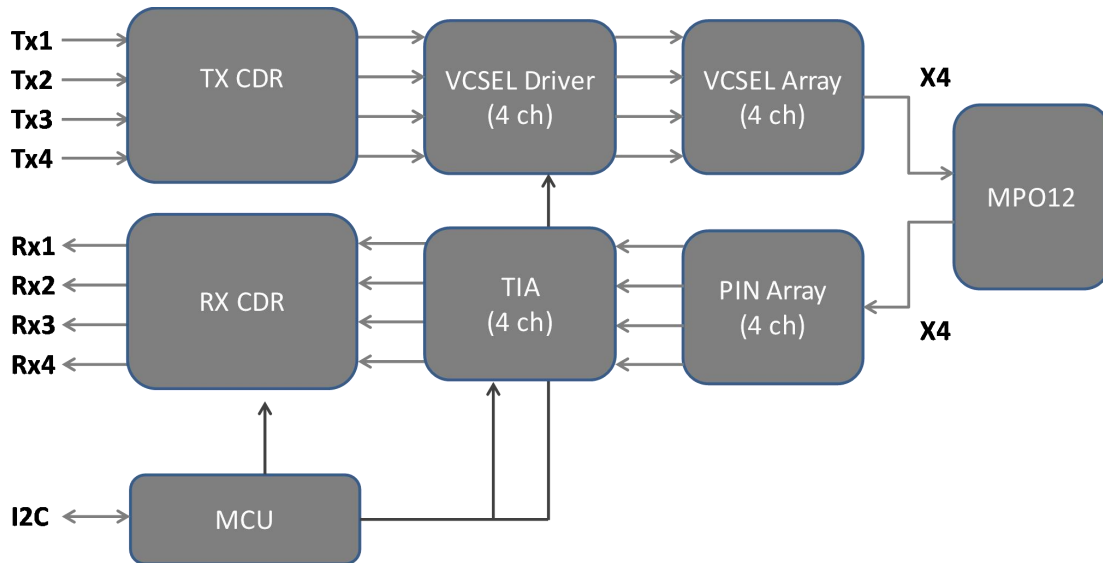

Figure 1. Module Block Diagram

Absolute Maximum Ratings

Parameter	Symbol	Min	Max	Unit
Supply Voltage	V_{cc}	-0.3	3.6	V
Input Voltage	V_{in}	-0.3	$V_{cc}+0.3$	V
Storage Temperature	T_s	-20	85	°C
Case Operating Temperature	T_c	0	70	°C
Humidity (non-condensing)	Rh	5	95	%

Recommended Operating Conditions

Parameter	Symbol	Min	Typical	Max	Unit
Supply Voltage	V_{cc}	3.13	3.3	3.47	V
Operating Case Temperature	T_c	0		70	°C
Baud Rate per Lane (PAM4)	fd		26.5625		GBaud/s
Humidity	Rh	5		85	%
Power Dissipation	P_m		4.1	4.5	W
Fiber Bend Radius	R_b	3			cm

Electrical Specifications

Parameter	Symbol	Min	Typical	Max	Unit
Differential Input Impedance	Z_{in}	90	100	110	ohm
Differential Output Impedance	Z_{out}	90	100	110	ohm
Differential Input Voltage Amplitude ^{Note3}	ΔV_{in}	300		900	mVpp
Differential Output Voltage Amplitude	ΔV_{out}	300		900	mVpp
Bit Error Rate ^{Note4}	BER			2.4E-4	
Input Logic Level High	V_{IH}	2.0		V_{cc}	V
Input Logic Level Low	V_{IL}	0		0.8	V

Output Logic Level High	V_{OH}	$V_{cc}-0.5$		V_{cc}	V
Output Logic Level Low	V_{OL}	0		0.4	V

Note:

Note3. Suggested < 700mVpp input differential signal for better BER performance.

Note4. Compliant with 200GBASE-SR4 electrical specification in IEEE802.3cd standard.

Optical Characteristics

Parameter	Symbol	Min	Typical	Max	Unit
Transmitter					
Center Wavelength	λ_c	840	850	860	nm
RMS Spectral Width	$\Delta\lambda$			0.6	nm
Average Launch Power (each lane)	P_{out}	-6		4	dBm
Outer Optical Modulation Amplitude (each lane)	OMA_{out}	-4		3	dBm
Launch power in OMA_{outer} minus TDECQ	P_{tdecq}	-5.9			dBm
Transmitter and dispersion eye closure (each lane)	TDECQ			4.9	dB
Average launch power of off transmitter(each lane)	P_{off}			-30	dBm
Outer Extinction Ratio	ER	3			dB
Optical Return Loss Tolerance	ORLT			12	dB
Receiver					
Center Wavelength	λ_c	840	850	860	nm
Damage threshold	R_{dam}	5			dBm
Average Receive Power (each lane)	P_{in}	-7.9		4	dBm
Receiver Power (OMA_{outer}) (each lane)	OMA_{out}			3	dBm
Receiver reflectance	P_{ref}			-12	dB
Stressed Receiver Sensitivity (OMA_{outer}) (each lane)	Sens			-3	dBm
Receiver Sensitivity (OMA_{outer}) (each lane) ^{Note5}	Sen			-7	dB

Note:

Note5. Measured with conformance test signal at TP3 for the BER specified in section 138.1.1 of IEEE 802.3cd.

Pin Description

Pin	Logic	Symbol	Name/Description
1		GND	Module Ground ^{Note6}
2	CML-I	Tx2-	Transmitter inverted data input
3	CML-I	Tx2+	Transmitter non-inverted data input
4		GND	Module Ground ^{Note6}
5	CML-I	Tx4-	Transmitter inverted data input
6	CML-I	Tx4+	Transmitter non-inverted data input
7		GND	Module Ground ^{Note6}
8	LVTTL-I	MODSEIL	Module Select ^{Note7}
9	LVTTL-I	ResetL	Module Reset ^{Note7}
10		VCCR _x	+3.3V Receiver Power Supply
11	LVC MOS-I	SCL	2-wire Serial interface clock ^{Note7}

12	LVC MOS-I/O	SDA	2-wire Serial interface data ^{Note7}
13		GND	Module Ground ^{Note6}
14	CML-O	RX3+	Receiver non-inverted data output
15	CML-O	RX3-	Receiver inverted data output
16		GND	Module Ground ^{Note6}
17	CML-O	RX1+	Receiver non-inverted data output
18	CML-O	RX1-	Receiver inverted data output
19		GND	Module Ground ^{Note6}
20		GND	Module Ground ^{Note6}
21	CML-O	RX2-	Receiver inverted data output
22	CML-O	RX2+	Receiver non-inverted data output
23		GND	Module Ground ^{Note6}
24	CML-O	RX4-	Receiver inverted data output
25	CML-O	RX4+	Receiver non-inverted data output
26		GND	Module Ground ^{Note6}
27	LVTTL-O	ModPrsL	Module Present, internal pulled down to GND
28	LVTTL-O	IntL	Interrupt output, should be pulled up on host board ²
29		VCCTx	+3.3V Transmitter Power Supply
30		VCC1	+3.3V Power Supply
31	LVTTL-I	LPMODE	Low Power Mode ^{Note7}
32		GND	Module Ground ^{Note6}
33	CML-I	Tx3+	Transmitter non-inverted data input
34	CML-I	Tx3-	Transmitter inverted data input
35		GND	Module Ground ^{Note6}
36	CML-I	Tx1+	Transmitter non-inverted data input
37	CML-I	Tx1-	Transmitter inverted data input
38		GND	Module Ground ^{Note6}

Note:

Note6. Module circuit ground is isolated from module chassis ground within the module.

Note7. Open collector should be pulled up with 4.7K to 10K ohms on host board to a voltage between 3.15V and 3.6V.

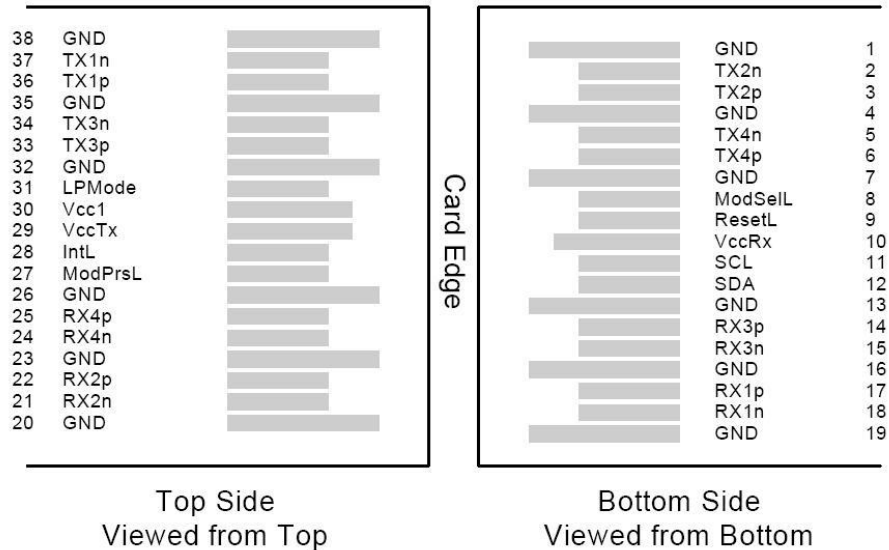

Figure 2. Electrical Pin-out Details

ModSelL Pin

The ModSelL is an input pin. When held low by the host, the module responds to 2-wire serial communication commands. The ModSelL allows the use of multiple QSFP modules on a single 2-wire interface bus. When the ModSelL is "High", the module will not respond to any 2-wire interface communication from the host. ModSelL has an internal pull-up in the module.

ResetL Pin

Reset. LPMode_Reset has an internal pull-up in the module. A low level on the ResetL pin for longer than the minimum pulse length (t_{Reset_init}) initiates a complete module reset, returning all user module settings to their default state. Module Reset Assert Time (t_{init}) starts on the rising edge after the low level on the ResetL pin is released. During the execution of a reset (t_{init}) the host shall disregard all status bits until the module indicates a completion of the reset interrupt. The module indicates this by posting an IntL signal with the Data_Not_Ready bit negated. Note that on power up (including hot insertion) the module will post this completion of reset interrupt without requiring a reset.

LPMode Pin

Gigalight QSFP28 modules operate in the low power mode (less than 1.5 W power consumption). This pin active high will decrease power consumption to less than 1W.

ModPrsL Pin

ModPrsL is pulled up to Vcc on the host board and grounded in the module. The ModPrsL is asserted "Low" when the module is inserted and deasserted "High" when the module is physically absent from the host connector.

IntL Pin

IntL is an output pin. When "Low", it indicates a possible module operational fault or a status critical to the host system. The host identifies the source of the interrupt by using the 2-wire serial interface. The IntL pin is an open collector output and must be pulled up to Vcc on the host board.

Power Supply Filtering

The host board should use the power supply filtering shown in Figure 3.

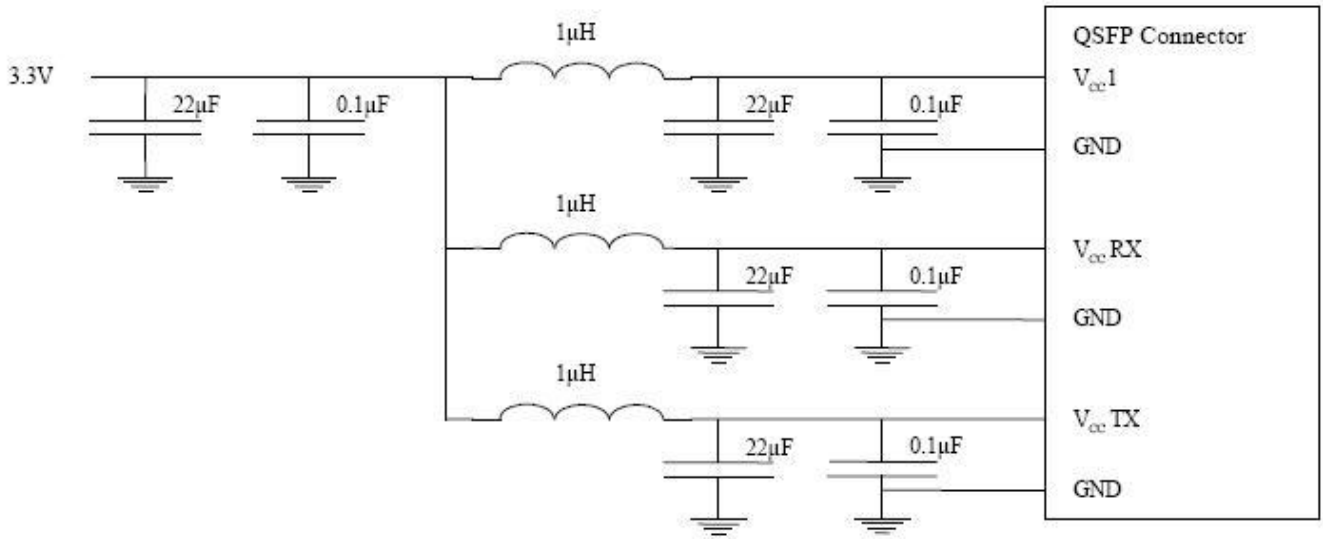
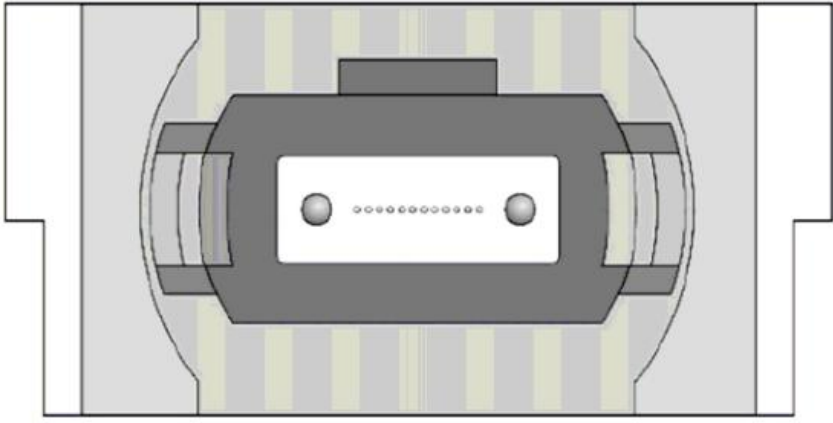

Figure 3. Host Board Power Supply Filtering

Optical Interface Lanes and Assignment

The optical interface port is a male MPO connector. The four fiber positions on the left as shown in Figure 4, with the key up, are used for the optical transmit signals (Channel 1 through 4). The fiber positions on the right are used for the optical receive signals (Channel 4 through 1). The central four fibers are physically present.



Transmit Channels: 1 2 3 4
 Unused positions: x x x x
 Receive Channels: 4 3 2 1

Figure 4. Optical Receptacle and Channel Orientation

DIAGNOSTIC MONITORING INTERFACE

Digital diagnostics functions are available via the I2C interface as specified by SFF-8636.

The structure of the memory is shown in Figure 5. The memory space is arranged into a lower, single page, address space of 128 bytes and multiple upper address space pages. This structure permits timely access to addresses in the lower page, such as Interrupt Flags and Monitors. Less time critical time entries, such as serial

ID information and threshold settings, are available with the Page Select function.

The interface address used is A0xh and is mainly used for time critical data like interrupt handling in order to enable a one-time-read for all data related to an interrupt situation. After an interrupt, IntL, has been asserted, the host can read out the flag field to determine the affected channel and type of flag.

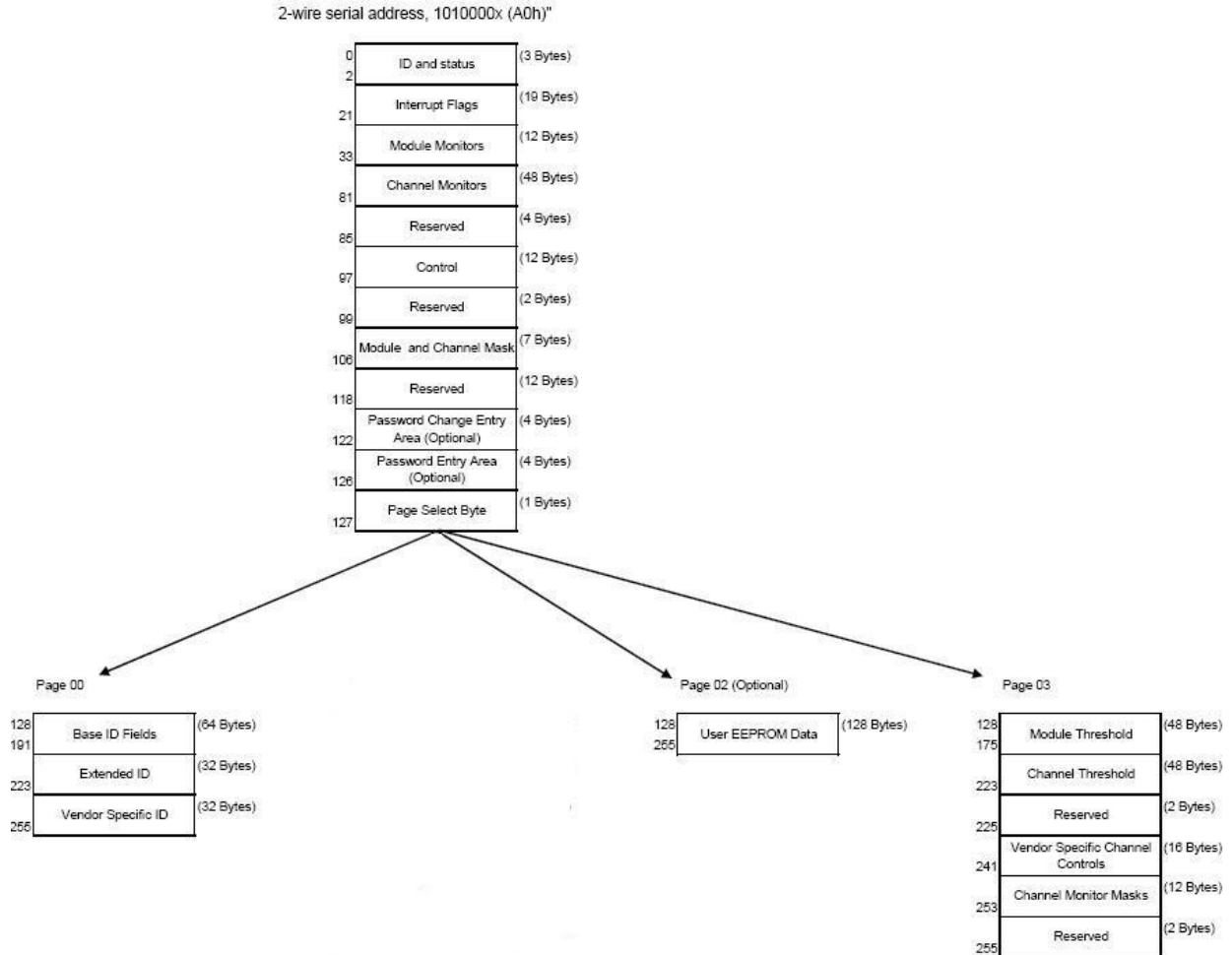

Figure 5. QSFP56 Memory Map

Byte Address	Description	Type
0	Identifier (1 Byte)	Read Only
1-2	Status (2 Bytes)	Read Only
3-21	Interrupt Flags (31 Bytes)	Read Only
22-33	Module Monitors (12 Bytes)	Read Only
34-81	Channel Monitors (48 Bytes)	Read Only
82-85	Reserved (4 Bytes)	Read Only
86-97	Control (12 Bytes)	Read/Write
98-99	Reserved (2 Bytes)	Read/Write
100-106	Module and Channel Masks (7 Bytes)	Read/Write
107-118	Reserved (12 Bytes)	Read/Write
119-122	Reserved (4 Bytes)	Read/Write
123-126	Reserved (4 Bytes)	Read/Write
127	Page Select Byte	Read/Write

Figure 6. Low Memory Map

Byte Address	Description	Type
128-175	Module Thresholds (48 Bytes)	Read Only
176-223	Reserved (48 Bytes)	Read Only
224-225	Reserved (2 Bytes)	Read Only
226-239	Reserved (14 Bytes)	Read/Write
240-241	Channel Controls (2 Bytes)	Read/Write
242-253	Reserved (12 Bytes)	Read/Write
254-255	Reserved (2 Bytes)	Read/Write

Figure 7. Page 03 Memory Map

Address	Name	Description
128	Identifier (1 Byte)	Identifier Type of serial transceiver
129	Ext. Identifier (1 Byte)	Extended identifier of serial transceiver
130	Connector (1 Byte)	Code for connector type
131-138	Transceiver (8 Bytes)	Code for electronic compatibility or optical compatibility
139	Encoding (1 Byte)	Code for serial encoding algorithm
140	BR, nominal (1 Byte)	Nominal bit rate, units of 100 Mbits/s
141	Extended RateSelect Compliance (1 Byte)	Tags for Extended RateSelect compliance
142	Length SMF (1 Byte)	Link length supported for SM fiber in km
143	Length E-50 μm (1 Byte)	Link length supported for EBW 50/125 μm fiber, units of 2 m
144	Length 50 μm (1 Byte)	Link length supported for 50/125 μm fiber, units of 1 m
145	Length 62.5 μm (1 Byte)	Link length supported for 62.5/125 μm fiber, units of 1 m
146	Length copper (1 Byte)	Link length supported for copper, units of 1 m
147	Device Tech (1 Byte)	Device technology
148-163	Vendor name (16 Bytes)	QSFP vendor name (ASCII)
164	Extended Transceiver (1 Byte)	Extended Transceiver Codes for InfiniBand [†]
165-167	Vendor OUI (3 Bytes)	QSFP vendor IEEE vendor company ID
168-183	Vendor PN (16 Bytes)	Part number provided by QSFP vendor (ASCII)
184-185	Vendor rev (2 Bytes)	Revision level for part number provided by vendor (ASCII)
186-187	Wavelength (2 Bytes)	Nominal laser wavelength (Wavelength = value / 20 in nm)
188-189	Wavelength Tolerance (2 Bytes)	Guaranteed range of laser wavelength (+/- value) from Nominal wavelength (Wavelength Tol = value / 200 in nm)
190	Max Case Temp (1 Byte)	Maximum Case Temperature in Degrees C
191	CC_BASE (1 Byte)	Check code for Base ID fields (addresses 128-190)
192-195	Options (4 Bytes)	Rate Select, TX Disable, TX Fault, LOS
196-211	Vendor SN (16 Bytes)	Serial number provided by vendor (ASCII)
212-219	Date code (8 Bytes)	Vendor's manufacturing date code
220	Diagnostic Monitoring Type (1 Byte)	Indicates which type of diagnostic monitoring is implemented
221	Enhanced Options (1 Byte)	Indicates which optional enhanced features are implemented
222	Reserved (1 Byte)	Reserved
223	CC_EXT	Check code for the Extended ID Fields (addresses 192-222)
224-255	Vendor Specific (32 Bytes)	Vendor Specific EEPROM

Figure 8. Page 00 Memory Map

Page02 is User EEPROM and its format decided by user.

The detail description of low memory and Page 00. Page 03 upper memory please see SFF-8636 document.

Timing for Soft Control and Status Functions

Parameter	Symbol	Max	Unit	Conditions
Initialization Time	t_init	2000	ms	Time from power on ^{Note8} , hot plug or rising edge of Reset until the module is fully functional ^{Note9}
Reset Init Assert Time	t_reset_init	2	μs	A Reset is generated by a low level longer than the minimum reset pulse time present on the
Serial Bus Hardware Ready Time	t_serial	2000	ms	Time from power on ^{Note8} until module responds to data transmission over the 2-wire serial bus
Monitor Data Ready Time	t_data	2000	ms	Time from power on ^{Note8} to data not ready, bit 0 of Byte 2, de-asserted and IntL asserted

Reset Assert Time	t_reset	2000	ms	Time from rising edge on the ResetL pin until the module is fully functional ^{Note9}
LPMODE Assert Time	ton_LPMODE	100	µs	Time from assertion of LPMODE (V_{in} : LPMODE= V_{IH}) until module power consumption enters lower Power Level
IntL Assert Time	ton_IntL	200	ms	Time from occurrence of condition triggering IntL until V_{out} : IntL= V_{OL}
IntL Deassert Time	toff_IntL	500	µs	Time from clear on read ^{Note10} operation of associated flag until V_{out} : IntL= V_{OH} . This includes deassert times for Rx LOS, Tx Fault and other flag bits.
Rx LOS Assert Time	ton_los	100	ms	Time from Rx LOS state to Rx LOS bit set and IntL asserted
Tx Fault Assert Time	ton_Txfault	200	ms	Time from Tx Fault state to Tx Fault bit set and IntL asserted
Flag Assert Time	ton_flag	200	ms	Time from occurrence of condition triggering flag to associated flag bit set and IntL asserted
Mask Assert Time	ton_mask	100	ms	Time from mask bit set ^{Note11} until associated IntL assertion is inhibited
Mask Deassert Time	toff_mask	100	ms	Time from mask bit cleared ^{Note11} until associated IntL operation resumes
ModSelL Assert Time	ton_ModSelL	100	µs	Time from assertion of ModSelL until module responds to data transmission over the 2-wire
ModSelL Deassert Time	toff_ModSelL	100	µs	Time from deassertion of ModSelL until the module does not respond to data transmission over the 2-wire serial bus
Power_override or Power-set Assert Time	ton_Pdown	100	ms	Time from P_Down bit set ^{Note11} until module power consumption enters lower Power Level
Power_override or Power-set Deassert	toff_Pdown	300	ms	Time from P_Down bit cleared ^{Note11} until the module is fully functional ^{Note10}

Note:

Note8. Power on is defined as the instant when supply voltages reach and remain at or above the minimum specified value.

Note9. Fully functional is defined as IntL asserted due to data not ready bit, bit 0 byte 2 de-asserted.

Note10. Measured from falling clock edge after stop bit of read transaction.

Note11. Measured from falling clock edge after stop bit of write transaction.

Mechanical Dimensions

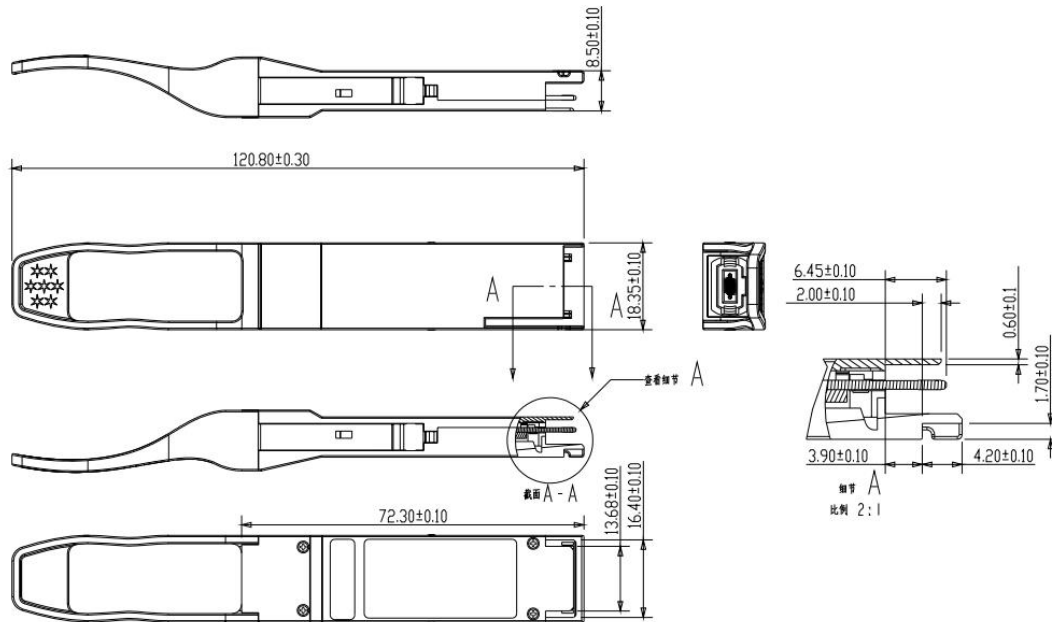

Figure 9. Mechanical Specifications

Regulatory Compliance

QSFP56 transceivers are Class 1 Laser Products. They are certified per the following standards:

Feature	Agency	Standard
Laser Eye Safety	FDA/CDRH	CDRH 21 CFR 1040 and Laser Notice 50
EMC	FCC	47 CFR FCC Part 15 Subpart B
EMC	CE-EMC	EN 55032:2015 EN 55024:2010+A1:2015 EN 61000-3-2:2014 EN 61000-3-3:2013

Complies with FDA performance standards for laser products except for deviations pursuant to Laser Notice No. 50, dated June 24, 2007.

References

1. QSFP MSA
2. SFF-8636
3. IEEE 802.3cd 200GBASE-SR4 specification
4. Directive 2011/65/EU of the European Parliament and of the Council, “on the restriction of the use of certain hazardous substances in electrical and electronic equipment,” July 1, 2011.