

ETP-NS11-20CP0

EPON OLT T1490nm/R1310nm PX20+, SFP Transceiver

Features

- Single fiber bi-directional data links symmetric 1.25Gbps application
- 1490nm continuous-mode DFB laser transmitter and 1310nm burst-mode APD-TIA receiver
- Reset-less burst-mode receiver simplify the system design
- More than 24dB wide dynamic range
- 0 to 70° C operating case temperature,
- Single 3.3V power supply
- Digital diagnostic monitoring interface
- Digital burst RSSI function to monitor the input optical power level
- LVPECL compatible data input/output interface
- LVTTTL transmitter disable control
- LVTTTL transmitter laser fault alarm
- LVTTTL receiver loss of signal indication
- Low EMI and excellent ESD protection
- Class I laser safety standard IEC-60825 compliant
- RoHS-6 compliance



Applications

- Gigabit Ethernet Passive Optical Networks (GEPON) 20Km 1:32 application or 10Km 1:64 application.

Standards

- Complies with SFP Multi-Source Agreement (MSA) SFF-8074i
- Complies with SFF-8472
- Complies with IEEE 802.3ah™-2004
- Complies with FCC 47 CFR Part 15, Class B
- Complies with FDA 21 CFR 1040.10 and 1040.11 except for deviations pursuant to Laser Notice No. 50.

Absolute Maximum Ratings

Table 1 - Absolute Maximum Ratings

| Parameter | Symbol | Min | Max | Unit | Note |
|-----------------------------|------------------|-----|-----|------|------|
| Storage Ambient Temperature | T _{STG} | -40 | 85 | °C | |
| Operating Case Temperature | T _c | 0 | 70 | °C | |
| Operating Humidity | OH | 5 | 90 | % | |
| Power Supply Voltage | V _{cc} | 0 | 3.6 | V | |
| Receiver Damaged Threshold | | +4 | | dBm | |

Recommended Operating Environment

Table 2 - Recommended Operating Environment

| Parameter | Symbol | Min | Typical | Max | Unit | Notes |
|----------------------------|-----------------|------|---------|------|--------|-------|
| Operating Case Temperature | T _c | 0 | | 70 | °C | |
| Power Supply Voltage | V _{cc} | 3.13 | 3.3 | 3.47 | V | |
| Operating Humidity Range | OH | 5 | | 90 | % | |
| Data Rate | | | 1.25 | | Gbit/s | |
| Data Rate Drift | | -100 | | +100 | PPM | |

Transmitter Optical Characteristics

Table 3- Transmitter Optical Characteristics

| Parameter | Symbol | Min | Typical | Max | Unit | Notes |
|-------------------------------------|-----------------|------|---------|------|------|---|
| Optical Center Wavelength | λ_c | 1480 | 1490 | 1500 | nm | |
| Optical Spectrum Width (-20dB) | $\Delta\lambda$ | | | 1 | nm | |
| Side Mode Suppression Ratio | SMSR | 30 | | | dB | |
| Average Launch Optical Power | AOP | +2 | | +7 | dBm | EOL, Over Temperature |
| Power-OFF Transmitter Optical Power | | | | -39 | dBm | Launched into SMF |
| Extinction Ratio | ER | 9 | | | dB | PRBS 2 ⁷ -1 test pattern @1.25Gbit/s |
| Total Jitter | TJ | | | 0.43 | UI | PRBS 2 ⁷ -1 test pattern @1.25Gbit/s |

| | | | | | |
|------------------------------------|---------------------------------------|--|------|-------|----------------------------|
| Rise / Fall Time (20%-80%) | T_R/T_F | | 260 | ps | Bessel-Thompson Filter OFF |
| RIN_{15OMA} | | | -115 | dB/Hz | |
| Optical Return Loss Tolerance | | | 15 | dB | |
| Transmitter Reflectance | | | -10 | dB | |
| Transmitter and Dispersion Penalty | TDP | | 2.3 | dB | Transmit on 20km SMF |
| Optical Waveform Diagram | Compliant with IEEE Std 802.3ah™-2004 | | | | See the figure below |

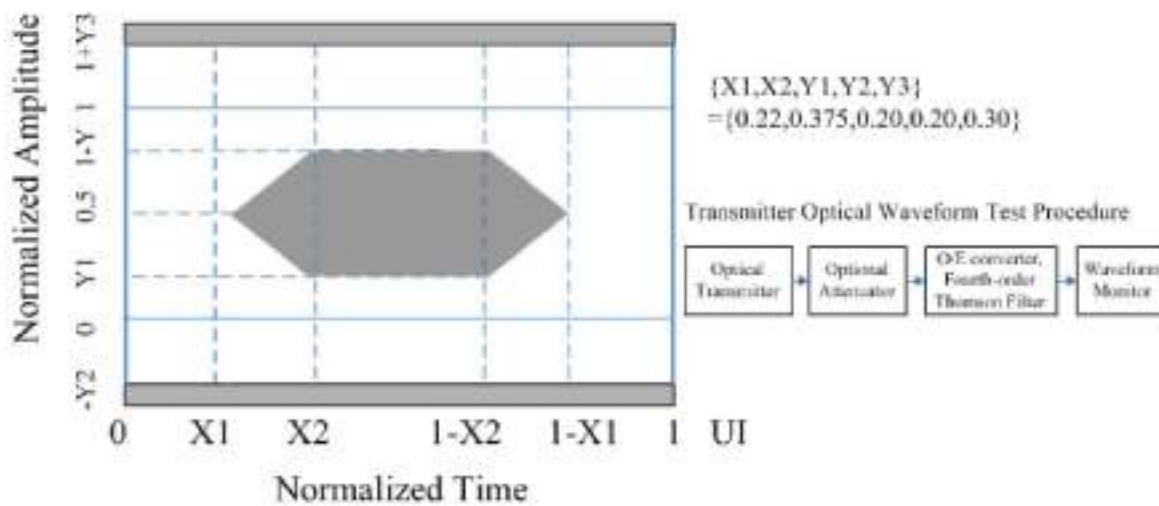

Digital Diagnostic Monitoring

Table 4- Digital Diagnostic Monitoring

| Parameter | Range | Accuracy | Calibration | Note |
|------------------|----------------|----------|-------------|---------------|
| Temperature | 0 to +70 °C | ±3°C | Internal | LSB: 1/256° C |
| Voltage | 2.97 to 3.63 V | ±3% | Internal | LSB: 0.1mV |
| Bias Current | 0 to 100 mA | ±10% | Internal | LSB: 2uA |
| TX Power | -2 to 8 dBm | ±3dB | Internal | LSB: 0.1uW |
| RX Power Monitor | -30 to -6 dBm | ±3dB | Internal | LSB: 0.1uW |

Transmitter Electrical Characteristics

Table 5- Transmitter Electrical Characteristics

| Parameter | Symbol | Min | Typical | Max | Unit | Notes |
|--|--------|-----|---------|-----------------|----------|--------------------------|
| Data Input Differential Swing | | 200 | | 1600 | mV | LVPECL input, AC coupled |
| Input Differential Impedance | | 90 | 100 | 110 | Ω | |
| Power Supply Current | | | | 220 | mA | Load free |
| Transmitter Disable Voltage - Low | | 0 | | 0.8 | V | |
| Transmitter Disable Voltage - High | | 2.0 | | V _{CC} | V | |
| Transmitter Fault Alarm Voltage - Low | | 0 | | 0.4 | V | |
| Transmitter Fault Alarm Voltage - High | | 2.4 | | V _{CC} | V | |

Receiver Optical Characteristics

Table 6- Receiver Optical Characteristics

| Parameter | Symbol | Min | Typical | Max | Unit | Notes |
|--------------------------------|--------|------|---------|------|------|---|
| Operating Wavelength | | 1260 | | 1360 | nm | |
| Sensitivity | SEN | | | -30 | dBm | PRBS 2 ²³ -1+72CID@124 4Mbps BER $\leq 1 \times 10^{-10}$ |
| Saturation Optical Power | SAT | -6 | | | dBm | |
| Loss Of Signal De-assert Level | LOSD | | | -31 | dBm | |
| Loss Of Signal Assert Level | LOSA | -45 | | | dBm | |
| Loss Of Signal Hysteresis | | 0.5 | | 6 | dB | |
| Receiver Reflectance | | | | -12 | dB | |
| Dynamic Range | | 30 | | -6 | dBm | See the figure below |

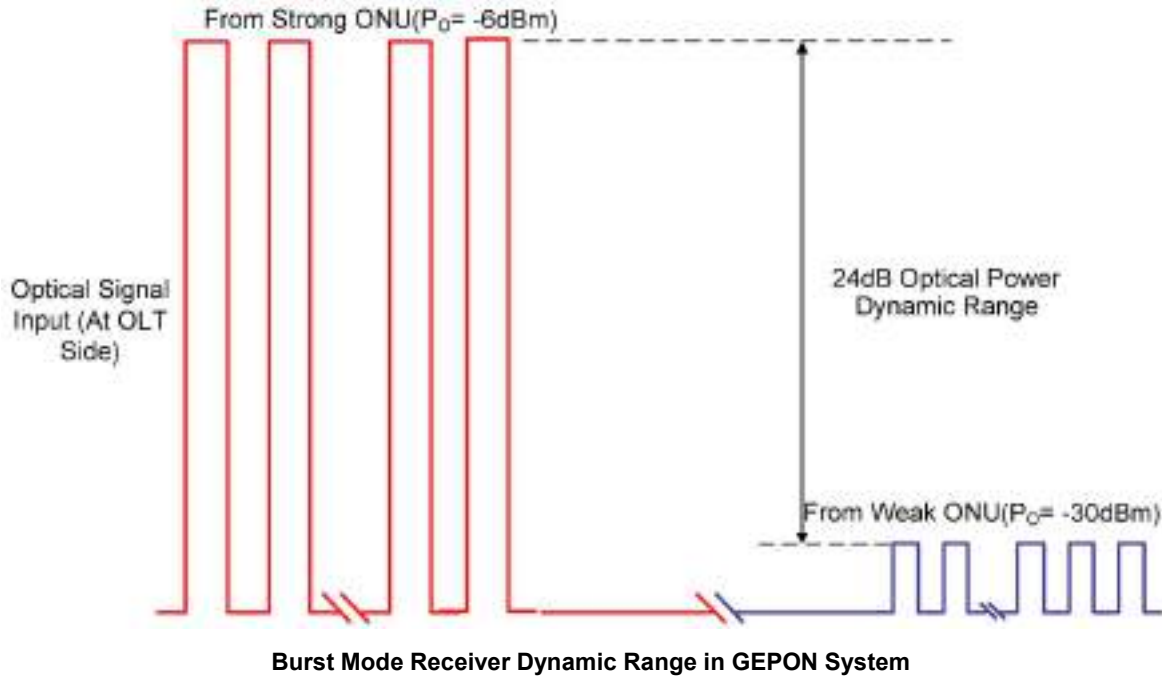

Receiver Electrical Characteristics

Table 7- Receiver Electrical Characteristics

| Parameter | Symbol | Min | Typical | Max | Unit | Notes |
|-----------------------------------|----------------|-------|---------|-------|---------|---------------------------|
| Power Supply Current | | | | 160 | mA | Load free |
| Data Output Voltage - Low (-Vcc) | | -1.81 | | -1.62 | V | |
| Data Output Voltage - High (-Vcc) | | -1.02 | | -0.88 | V | |
| Data Output Differential Swing | | 400 | | 1600 | mV | LVPECL output, DC coupled |
| Loss Of Signal Assert Time | | | 0.5 | | μ s | |
| Loss Of Signal Deassert Time | | | 0.5 | | μ s | |
| Loss Of Signal Voltage - Low | | 0 | | 0.4 | V | |
| Loss Of Signal Voltage - High | | 2.4 | | Vcc | V | |
| Receiver Threshold Settling Time | $T_{SETTLING}$ | | | 250 | ns | See the figure below |

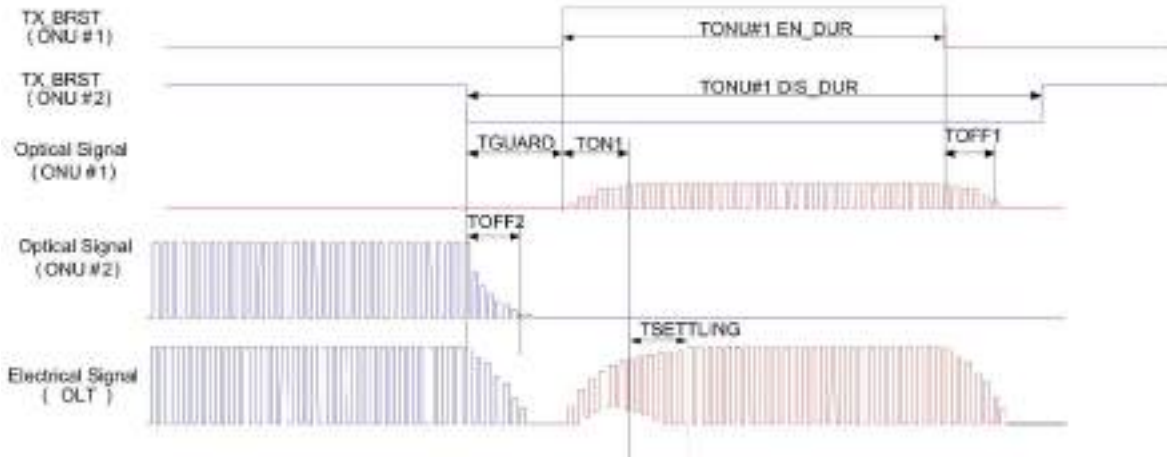

Timing Parameter Definitions in Burst More Sequence

Receiver Electrical Characteristics

Table 8- Receiver Electrical Characteristics

| Parameter | Symbol | Min | Typical | Max | Unit | Notes |
|----------------------------|-------------|------|---------|-----|---------|------------------------------------|
| RSSI Trigger-Low | | 0 | | 0.8 | V | |
| RSSI Trigger-High | | 2.0 | | Vcc | V | |
| RSSI Trigger width | T_w | 10 | | | us | |
| RSSI Trigger Delay | T_D | | 950 | | ns | Refer to first bit of the preamble |
| I2C Access Prohibited Time | | 150 | 200 | | μ s | |
| Optical Signal During Time | TONU EN_DUR | 1000 | 1200 | | ns | 400ns CDR time |

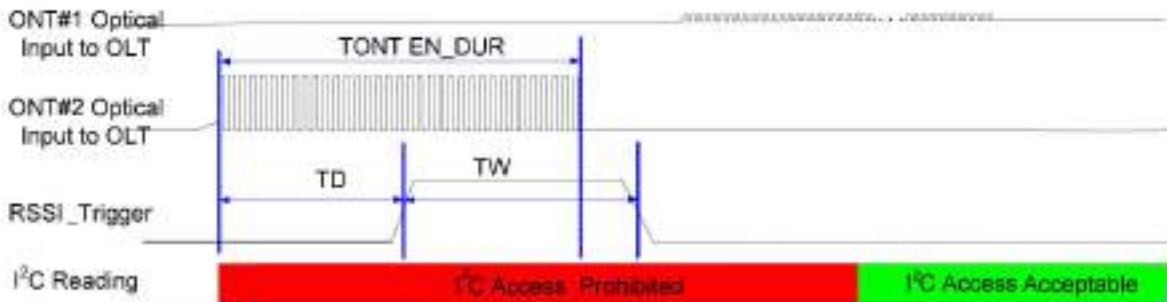

RSSI Timing Sequence

Pin Assignment

Pin Diagram

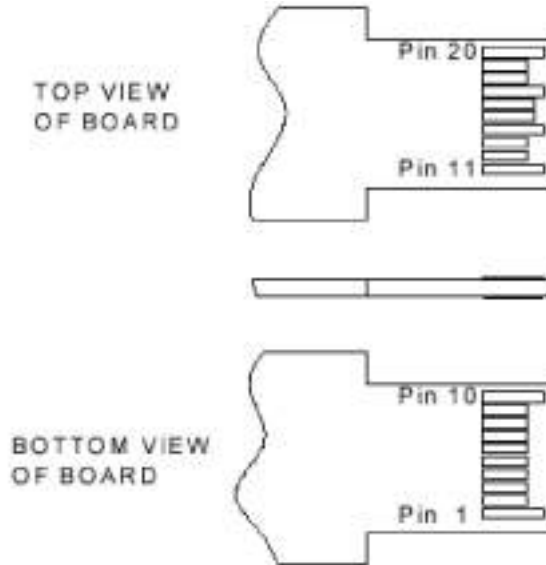

Pin Descriptions

Table 9-Pin Descriptions

| Pin | Name | Description | Note |
|-----|-------------------|---|---|
| 1 | V _{EE} T | Transmitter Ground | |
| 2 | TX Fault | Transmitter Fault Indication | High: abnormal; Low: normal |
| 3 | TX Disable | Transmitter Disable | High: transmitter disable; Low: transmitter enable |
| 4 | MOD-DEF2 | Module Definition 2 | The data line of two wire serial interface |
| 5 | MOD-DEF1 | Module Definition 1 | The clock line of two wire serial interface |
| 6 | MOD-DEF0 | Module Definition 0 | Connected to Ground in the transceiver |
| 7 | RSSI Trigger | RSSI Trigger for Transceiver A/D Conversion | High: enable RSSI A/D conversion |
| 8 | LOS | Loss of Signal | High: Loss of signal Low: Signal Detected |
| 9 | V _{EE} R | Receiver Ground | |
| 10 | V _{EE} R | Receiver Ground | |
| 11 | V _{EE} R | Receiver Ground | |
| 12 | RD- | Inv. Receiver Data Out | LVPECL logic output, DC coupled |
| 13 | RD+ | Receiver Data Out | LVPECL logic output, DC coupled |

| | | | |
|----|-------------------|-----------------------|--------------------------------|
| 14 | V _{EE} R | Receiver Ground | |
| 15 | V _{CC} R | Receiver Power | |
| 16 | V _{CC} T | Transmitter Power | |
| 17 | V _{EE} T | Transmitter Ground | |
| 18 | TD+ | Transmit Data In | LVPECL logic input, AC coupled |
| 19 | TD- | Inv. Transmit Data In | LVPECL logic input, AC coupled |
| 20 | V _{EE} T | Transmitter Ground | |

SFP Recommended Host Board Power Supply Filtering Network

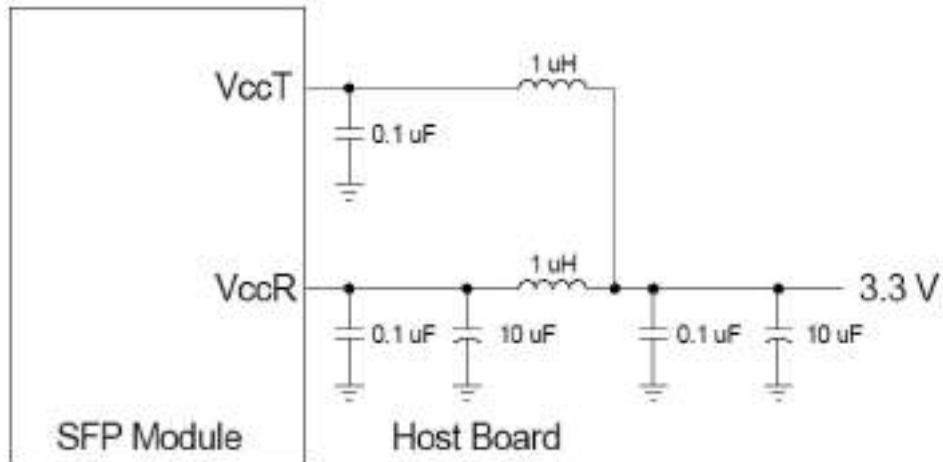

Typical Interface Circuit

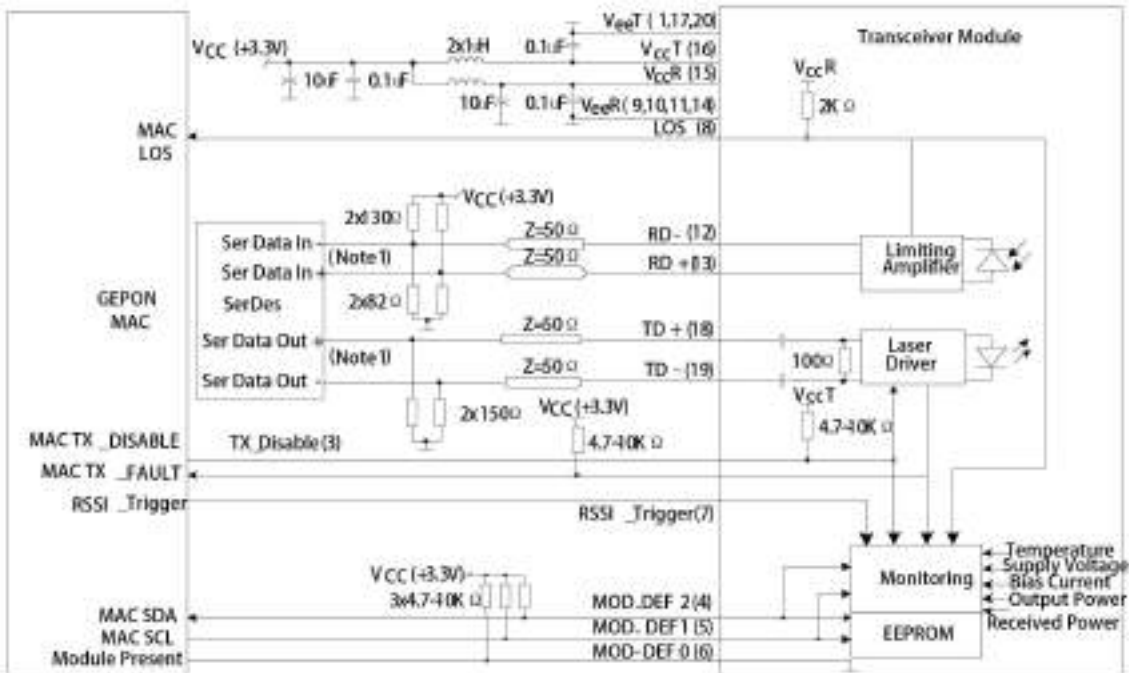

EEPROM Information

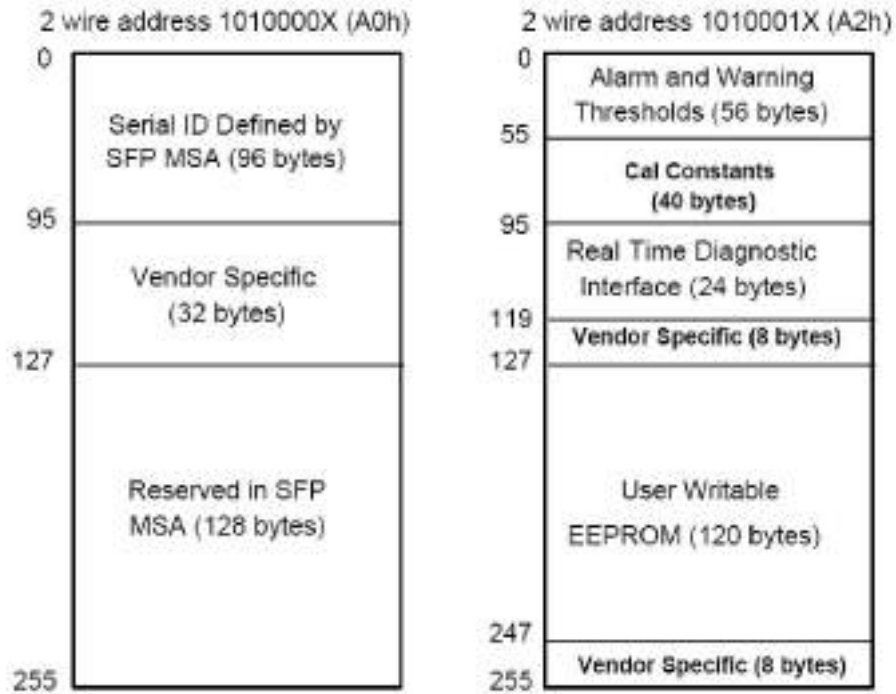

Mechanical Specifications

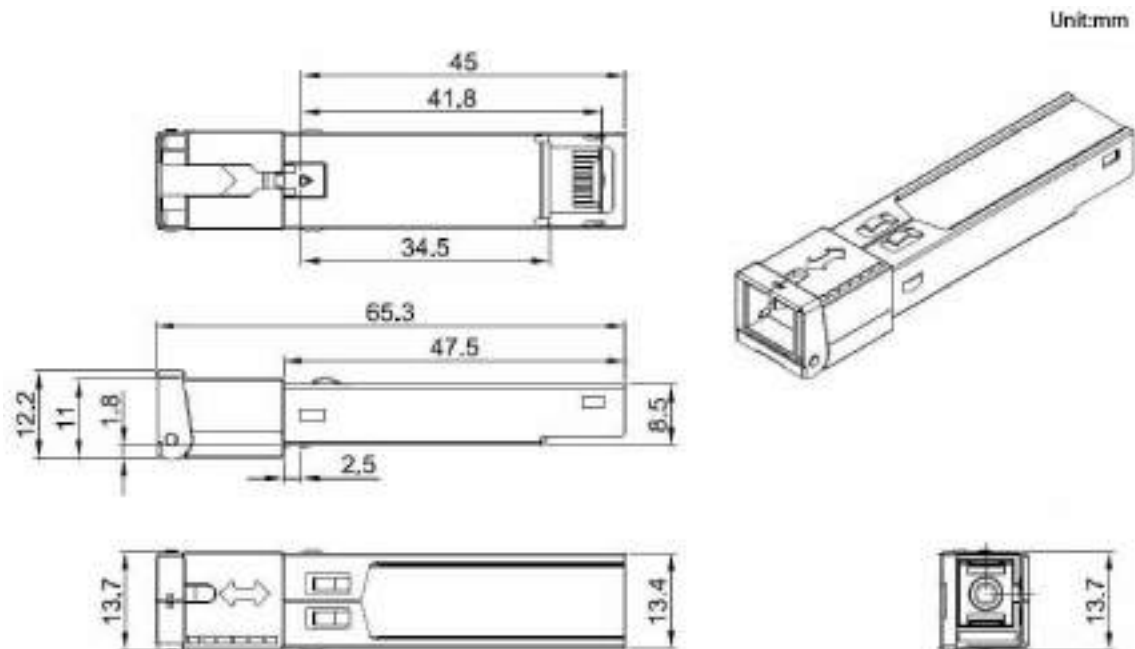

Ordering information

Table 10- Ordering information

| Part Number | Product Description |
|----------------|--|
| ETP-NS11-20CP0 | 1.25G/1.25G - EPON OLT SFP Tx 1490nm/ Rx 1310nm SC PX20+ 0 ~ +70°C, with DDM |