

AW-D138 is a smoke with fixed temperature and rate-of-rise heat detector. The detector uses an optical sensing chamber to detect smoke and a fixed-temperature heat sensor to detect heat from fire. It is designed to provide open area protection.

The red LED on the detector provides a local 360° visible alarm indication.

The detector that initiated the alarm condition will have its red LED latched until reset by panel.



Features

- ✓ Low Standby current for continuous monitoring
- ✓ Two-wire connection
- ✓ Dual LED design provides 360° viewing angle
- ✓ Meet requirement of EN54-5:2017 & EN54-7:2018

Installation

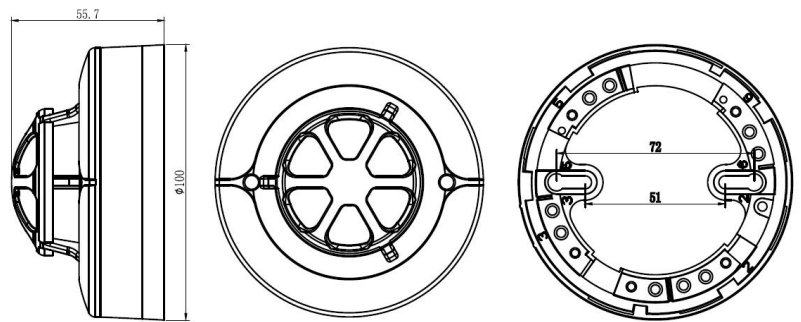

Technical Specification

Model	AW-D138
Operating voltage	18~28VDC @Loop
Operating current(@Loop 24VDC)	Monitoring status≤1.5mA, Alarm status≤2.5mA @24VDC
Application	For indoor use only
Wiring	The promise of two bus system(Loop in, Loop out)
Smoke alarm sensitivity	0.18~0.3dB/m
Fixed temperature alarm	57°C (135°F) A2R
Environmental	Temperature range: -10~50°C (14~122°F) Humidity: 5 to 95% RH, non-condensing
Materials and colors	ABS, White
Mating host	AW-FP100 series addressable fire alarm control panel
Size	φ 100mm* 55.7mm installed in base
Weight	About 120g